

# ESSE

## 100 Series Instruction Manual

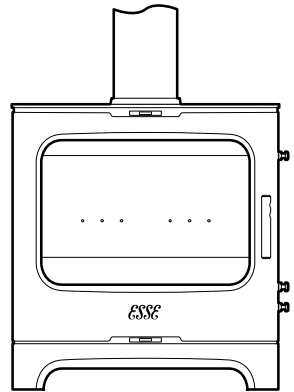

UK  
CA CE MADE IN  
BRITAIN

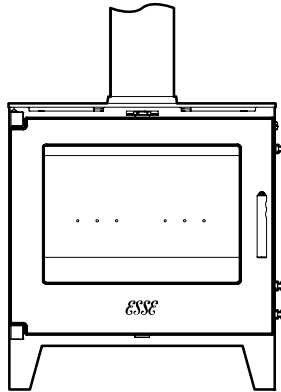
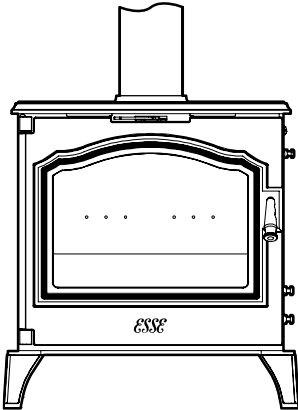

## CONTENTS

CONTENTS .....	2
<b>1. WELCOME TO YOUR ESSE.....</b>	<b>4</b>
<b>2. QUICK START GUIDE.....</b>	<b>5</b>
CO ALARM.....	6
<b>3. OPERATING INSTRUCTIONS.....</b>	<b>6</b>
VENTILATION .....	6
FUEL.....	6
WOOD LOGS .....	6
COMBUSTION AIR, AIRWASH & CONVECTION AIR.....	7
PARTICULATE REBURN™ TECHNOLOGY .....	9
LIGHTING YOUR ESSE STOVE.....	13
REFUELLING .....	14
REDUCED BURNING .....	14
THE FIRE GRATE AND RIDDLING .....	14
ASHPAN .....	15
CLEANING & MAINTENANCE.....	16
CHIMNEY SWEEPING.....	16
SAFE SHUTDOWN .....	16
SEASONAL USE.....	16
WARRANTY .....	17
TROUBLESHOOTING.....	17
PLANNING THE INSTALLATION.....	19
<b>4. INSTALLATION INSTRUCTIONS.....</b>	<b>19</b>
VENTILATION .....	19
PRODUCT SPECIFICATION – 100 SERIES .....	20
CO ALARM.....	20
UNPACKING THE APPLIANCE .....	20
TOP OR REAR FLUE CONNECTION.....	21
CHIMNEY & FLUE .....	22
HEARTH.....	22
CLEARANCE DISTANCES (COMBUSTIBLES & NON-COMBUSTIBLES).....	22

FLUE DRAFT .....	23
COMMISSIONING .....	23
<b>5. APPLIANCE COMMISSIONING CHECKLIST .....</b>	<b>24</b>
<b>6. CONSUMABLE PARTS.....</b>	<b>25</b>
<b>7. DECLARATION OF PERFORMANCE.....</b>	<b>26</b>

## 1. WELCOME TO YOUR ESSE

Welcome to the ESSE family. We've poured all of our knowledge, expertise and passion for designing and manufacturing market leading stoves, dating back to 1854, into producing your ESSE stove. All ESSE stoves are manufactured at our factory in Barnoldswick, Lancashire, and we're confident that if appropriately installed, maintained and cared for, your ESSE stove will provide you with many years of room heating, comfort and joy.

Before you fire up your ESSE stove for the first time, ensure that your installer has installed the stove in line with the 'Installation' section of this manual, and that the flue and chimney has been swept. The stove is not suitable for use in a shared flue.

As you would expect, when in use, all parts of the stove become hot, so always use the supplied operating tool or glove when interacting with your ESSE stove. A fireguard manufactured in accordance with BS 8423:2002 should be used, if it is likely that children or pets may come into contact with the appliance. The stove is suitable for intermittent operation. Do not use an aerosol spray close to the stove when alight.

These instructions provide all the necessary information to both install, then operate your ESSE stove. The key information relating to your stove, including the serial number, can be found on the data plate, located at the rear of the stove. Simply swing the data plate up to access the information. Please quote the model and serial number, in any future communication with your retailer or the manufacturer.

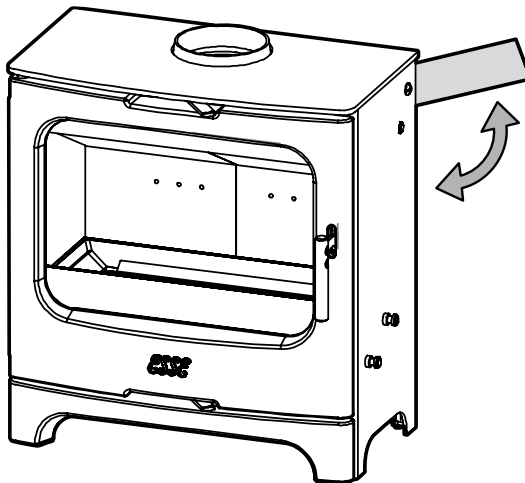

Data plate location

## 2. QUICK START GUIDE

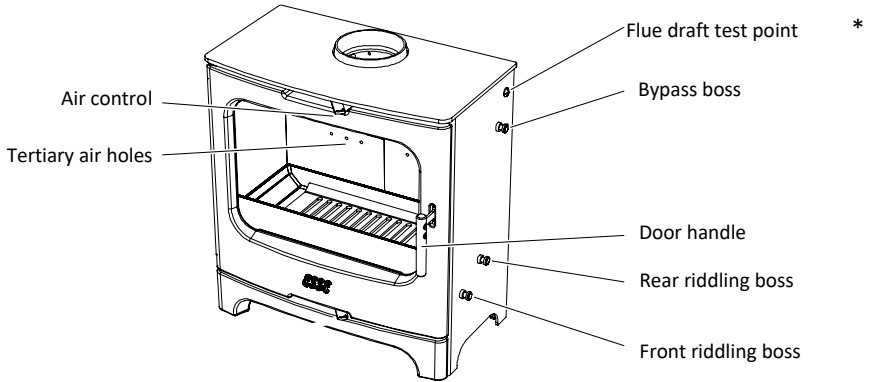

### INCLUDED WITH YOUR ESSE STOVE

✓	Instruction manual
✓	Stove glove
✓	Top flue blanking plate
✓	4 x Height adjusting bolts
✓	Energy label

### BEFORE LIGHTING THE STOVE

✓	Fully <b>close</b> fire grate
✓	Fully <b>open</b> Air Control
✓	Fully <b>open</b> the Bypass Boss

### LIGHTING THE STOVE

		
Place kindling wood on top of fire lighters / newspaper, and carefully light, leaving the door slightly ajar.	Once flames on the kindling have taken hold, add small logs, again leaving the door slightly ajar.	Once established, add larger logs, fully close the door, and adjust air control to control the fire.

## 3. OPERATING INSTRUCTIONS

### CO ALARM

Your installer should have ensured that you have a Carbon Monoxide (CO) alarm fitted, in the same room as your ESSE stove. This is a requirement of the BS EN 50292:2013 standard, and you should make sure that you are familiar with the operation of this essential piece of equipment.

### VENTILATION

All stoves require a consistent supply of 'combustion air', to allow for the combustion of the fire. As a general rule, permanent external air vents are not required for stoves with a nominal output of 5kW or less. However, some newer houses with a low air permeability may need a permanent external air vent, irrespective of the nominal output of the stove. Your installer will have advised you on the requirements, within your situation. For more information, see the 'Ventilation' section of the 'Installation Instructions' part of this document.

### FUEL

Your ESSE stove has been designed to burn wood logs, incorporating our unique 'Particulate Reburn™ Technology', which contributes to making it the cleanest wood-burning stove we've ever built.



This appliance is not appropriate for use as an incinerator, and unsuitable fuels should not be used. Failure to follow this requirement will invalidate your warranty.

### WOOD LOGS

Burning wood logs within your ESSE stove provides sustainable, efficient and 'clean' heating to your room. The moisture content of your wood is very important, as this affects both how 'cleanly' your stove will burn, and also how long the fuel will burn for. Referred to as 'green wood', recently felled wood will almost certainly have a moisture content that is too high to burn efficiently and cleanly. Similarly, overly dry wood will burn quickly, with higher emissions, making your stove less economical to run.

We recommend using wood logs with a moisture content of 15 – 20%. This is best achieved by either storing green wood yourself for a period of 12 – 18 months, and checking regularly with a moisture detector, or purchasing it from a reputable fire wood specialist, who is able to control the moisture content of their wood logs.

For best results, we recommend your wood logs are cut to a length of 200mm, and a diameter / width of 120mm.

#### Fuel Overloading

The maximum amount of fuel specified in this manual should not be exceeded, overloading can cause excess smoke.

## 3. OPERATING INSTRUCTIONS

### COMBUSTION AIR, AIRWASH & CONVECTION AIR

ESSE stoves are designed to achieve the most efficient heat outputs, with the 'cleanest burn'. To achieve this, significant research and development investment has been given to how to provide appropriate levels of 'combustion air' to the correct parts of the fire, at the correct time of the burn cycle.

Combustion air is drawn into your ESSE stove from two locations. Your ESSE stove also incorporates two further air management technologies, which provide additional benefits.

\*

2. Air Control
3. Tertiary air
4. Airwash
5. Convection air

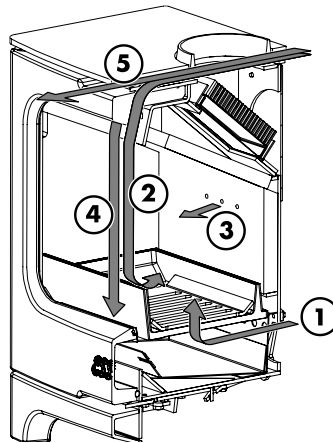

Combustion air, airwash & convection air

#### Air Control

Secondary Air enters your ESSE stove from the top of the appliance, dropping down into the firebox, via the 'Airwash' (see below). Secondary Air is used when burning both wood logs and solid mineral fuels. The Secondary Air control incorporates Precision Burn™ technology, to provide a more precise adjustment, to better control the air supply and burn rate. When moved to the right, there is more air and a fiercer burn rate, whilst moved to the left, there is less air, and softer burn rate.

#### Tertiary Air

Tertiary Air enters your ESSE stove from the rear, through the rear fire bricks, to provide additional combustion air directly into the flames. The Tertiary Air volume is not adjustable, but carefully positioned to help achieve improved efficiency and a clean burn.

#### Airwash

The Airwash is created by air being pushed down the inside face of the glass window, creating an air curtain that helps reduce build-up of soot, keeping the glass clean.

### 3. OPERATING INSTRUCTIONS

#### Convection Air

Your ESSE stove has an inbuilt Convection Air system, to help push hot air forward out of the stove, to better heat up the room. Natural convection draws cold air into the top of the stove through rear slots, which is heated up as it passes through the stove, before being pushed out into the room.

\*

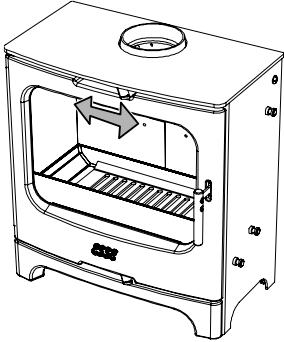

Air control, incorporating Precision Burn™ technology

#### Dampers left open

Operation with the air control or appliance dampers open can cause excess smoke. The appliance must not be operated with air controls, appliance dampers or door left open except as directed in the instructions.



### 3. OPERATING INSTRUCTIONS

#### PARTICULATE REBURN™ TECHNOLOGY

Your ESSE stove incorporates Particulate Reburn™ Technology, which dramatically reduces the emissions when burning wood logs, far above and beyond the demands of the Ecodesign requirements, (which comes into force in 2022). As such, your ESSE stove is one of the cleanest burning stoves available.

Particulate Reburn™ Technology creates three distinct areas of combustion within the stove, which both increases the heat generated from the wood log fuel, and dramatically reduces emissions, by burning more hydrocarbon particles than conventional stoves.

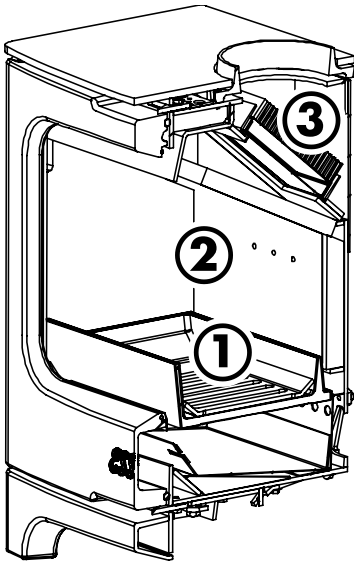

1. The initial combustion of wood logs, within the firebed.
2. A second area of combustion, where additional tertiary air is directed at unburnt hydrocarbon particles, contained within smoke rising up from the wood logs.
3. A third area of combustion, where remaining hydrocarbon particles pass through the catalytic combustor, which reduces the temperature required for the particles to combust, reigniting them.

The three areas of combustion from Particulate Reburn™ Technology

At the heart of the third area of combustion is the Catalytic Combustor, which uses a coating of noble metals to reduce the temperature required to achieve combustion, reigniting any unburnt hydrocarbon particles, as they pass through the chamber.

### 3. OPERATING INSTRUCTIONS

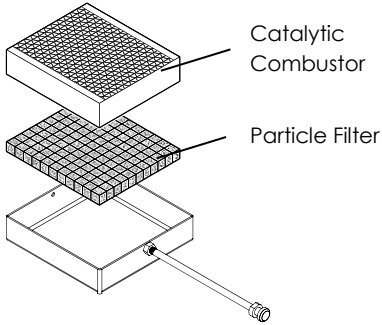

The catalytic combustor is positioned above a particle filter, and both are held together on a sliding cartridge. As a result, both parts can be simply moved to one side, allowing smoke to 'bypass' them, and pass directly up the flue.

The cartridge containing both parts can be removed for cleaning and inspection.

The catalytic combustor and particle filter, located within a sliding cartridge.



Do not burn wet wood logs, chemically treated timber or heavily printed glossy materials, (eg magazines), as this can damage the catalytic combustor.

#### **Bypassing the Catalytic Combustor**

The Catalytic Combustor is most efficient when your ESSE stove has reached a steady operating temperature. With this in mind, and so as to prologue its life, the Catalytic Combustor should be bypassed when lighting your ESSE stove, by simply pulling the 'Bypass Boss' out from the top right hand side of the stove. Once the fire has taken hold, the catalytic combustor can be positioned back into place. Similarly, it is advisable to bypass the catalytic combustor when refuelling your ESSE stove.

When fully opened, the bypass boss extends 150mm to the right of the stove. However, to successfully bypass the catalytic combustor, it must be opened to extend to a minimum of 75mm to the right of the stove.

\*

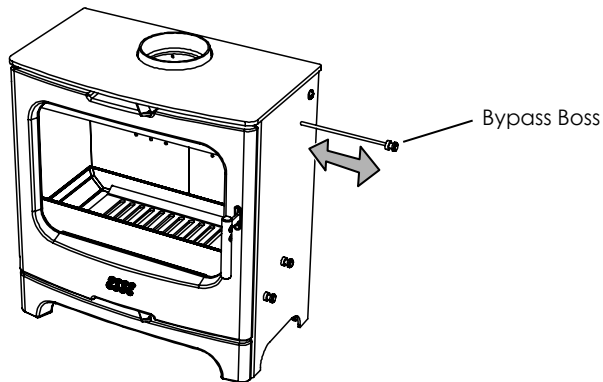

#### **Bypassing the catalytic combustor**

#### **Anticipated Life**

Well maintained and cared for, the Catalytic Combustor can remain effective for up to ten years. However, to ensure the continued cleanest

### 3. OPERATING INSTRUCTIONS

burn, and maximum efficiency, we recommend replacing the Catalytic Combustor every five to six years.

It is important to regularly inspect the Catalytic Combustor for signs of physical damage and build-up of creosote, which can lead to the airflow being blocked. In either of these scenarios, the Catalytic Combustor should be replaced. We recommend having the Catalytic Combustor inspected annually by your service professional, at the same time as the stove is inspected and the flue / chimney swept. Should your stove's efficiency and / or heat output drop, or if there is a noticeable increase in visible smoke emitting from your chimney, this may also suggest the need to replace the Catalytic Combustor.

#### **Maintenance**

To prolong the life of the Catalytic Combustor, and keep the efficiency and heat output of your ESSE stove high, both the Catalytic Combustor and Particle Filter should be cleaned regularly. We recommend having both parts cleaned annually by your service professional, at the same time as the stove is inspected and the flue / chimney swept. To do so, when the stove is cold, remove the both Catalytic Combustor and Particle Filter from the stove, and wrap them in a plastic bag. Gently tap both parts, one at a time, allowing any build-up of dust to fall into the bag, before removing the parts, sealing the bag, and disposing of it into a waste bin. Then either use a domestic vacuum cleaner or a soft bristle brush, to remove any remaining dirt within the two parts. Once cleaned, both parts should be repositioned within your ESSE stove.

### 3. OPERATING INSTRUCTIONS

#### Removal and replacement of the Catalytic Combustor and Particle Filter

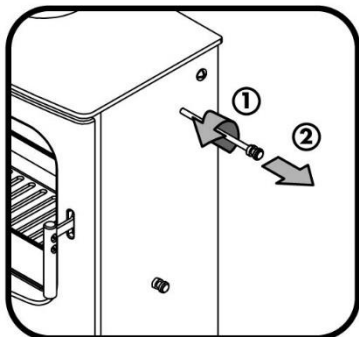

1. Remove the Bypass Boss from the shaft by unscrewing it anticlockwise.

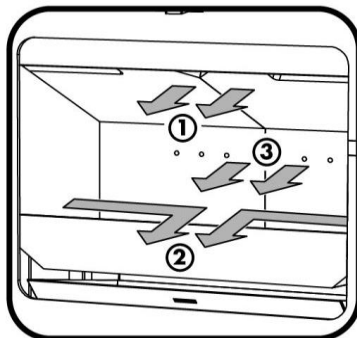

2. Remove the top, side then rear fire bricks.

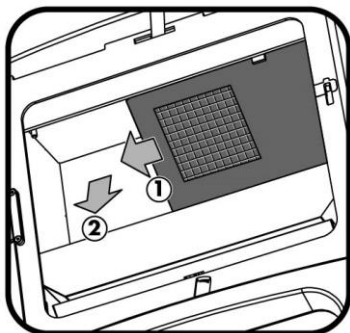

3. Slide the chamber containing the Catalytic Combustor and Particle Filter fully to the left, before carefully allowing it to swing down free.

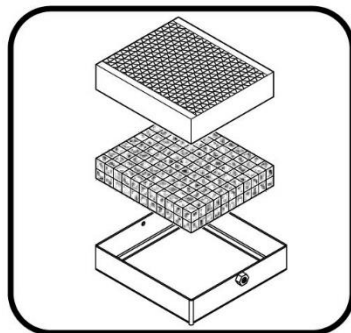

4. Remove the Catalytic Combustor and then the Particle Filter from the cartridge, for cleaning or replacement, retaining the sealing rope.

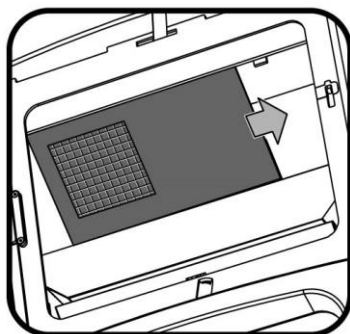

5. Once the two parts have been cleaned or replaced, reassemble the cartridge, reinstalling it along with the chamber into the stove, and slide into position.

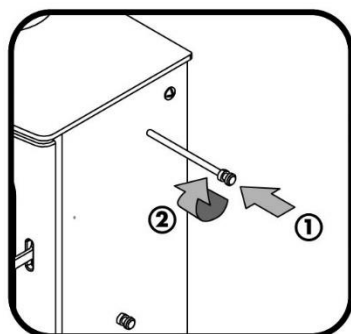

6. Reinstall the bypass boss, tightening up clockwise. Finally, replace the firebricks.

### 3. OPERATING INSTRUCTIONS

#### LIGHTING YOUR ESSE STOVE

When your ESSE stove is first lit, it may smoke, give off an odour, or make 'ticking noises'. This is quite normal, as the materials used within its manufacture are heated up for the first time. These symptoms will stop within a short period, but ensure that the room is well ventilated during this 'settling in' process.

The pallet that your ESSE stove was supplied on has been produced from timber that is appropriate for use as kindling, so can be broken up and chopped, for this purpose.

Initially only light a small fire, for a period of 1 – 2 hours, to dry out any moisture found within the flue and chimney.



Whilst lighting the fire, do not leave your ESSE stove unattended, until the fire is established, the door is fully closed, and you have adjusted the controller(s) to the appropriate level.



Before lighting your ESSE stove, ensure that the fire grate is fully closed, (pushed to the left), and that the Air Control is fully open (Pushed to the right). Pull out the Bypass Boss to the maximum distance.



Lay three small pieces of kindling wood next to each other in the centre of the grate, and place a few firelighters / tightly rolled up newspaper on top of them. On top, place two pieces of kindling wood at ninety degrees to the first three, either side of the firelighters / newspaper. Add three more pieces of kindling wood on top, in line with the bottom row, to create a small lattice structure. Safely light the firelighters / newspaper, and allow the flames to take hold.



Once the fire has taken hold, place two small wood logs onto the growing flames, and close the door, but leaving it slightly ajar. Once the flames have established on the small wood logs, (typically within 3 – 5 minutes), add the desired load of larger wood logs, and fully close the door. When the fire has fully established, slowly reduce the air volume, by moving the control to the left. Continue to use the Air Control to control the fire, until the flames are slowly 'dancing' on top of the wood logs.

We recommend a maximum load of wood logs of 1.75Kg / hour, which when stacked in the firebox, should not sit above the six Tertiary Air holes, located within the rear fire bricks.

### 3. OPERATING INSTRUCTIONS



The door should only be opened during the initial lighting and refuelling of your ESSE stove. If left open during normal operation, you may experience excessive smoke emitting into your room.

#### REFUELLING

Refuelling should be undertaken whilst the flames on the current fuel are still established, or you may experience excessive smoking. If the current fire has died out, reignite the fire with additional kindling, before adding additional fuel. When positioning fuel into the firebed, ensure that the fuel is not touching the back or side walls, or the glass window, as this will result in a less clean burn.

To enjoy optimum wood burning, leave an ashbed of 1 – 2cm of ash within the fire grate. First rake the current fuel, to create a bed of hot embers, on which to place the new fuel. Then place the new wood logs onto the hot embers. For the most efficient and cleanest burn, two wood logs should be placed in a 'V shape', as shown below. Close the door, and open the Air Control, to allow flames to take hold on the new wood logs. Once the fire is once again established, slowly reduce the secondary air volume, by moving the control to the left. Continue to use the Air Control to control the fire, until the flames are slowly 'dancing' on top of the wood logs.



Do not 'overload' the fire with excessive amounts of fuel, as this will result in over-firing, and may cause permanent damage to your ESSE stove.

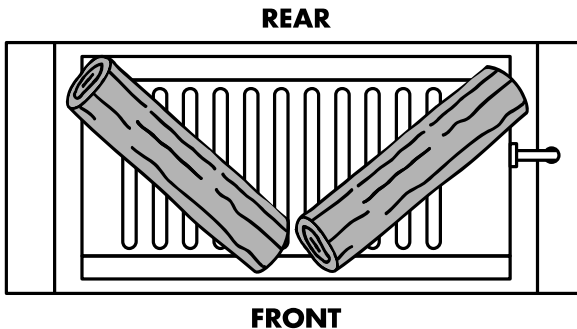

Optimum positioning of wood logs, when refuelling – Top View

#### REDUCED BURNING

Once a fire has established, close down the air control, and ensure that the door is firmly closed. Experimentation with the setting of air control may be required, depending upon the flue draft and fuel type. A build-up of soot on the inside face of the glass window is likely.

#### THE FIRE GRATE AND RIDDLING



Your ESSE stove will be hot during and after use. Always use the supplied Operating Tool and / or Stove Glove to riddle the appliance.

### 3. OPERATING INSTRUCTIONS

The Fire Grate in your ESSE stove is made of two parts – The Grate and the Riddle Plate. The Fire Grate can be ‘riddled’ by sliding the Riddle Plate quickly between the left and right position, forcing excess ash to fall through the slots in both parts, into the Ashpan below.

To ‘riddle’ the Fire Grate, position the straight end of the Operating Tool on the rear Riddling Boss, so it rests on the top of the front Riddling Boss. Alternate the Operating Tool position quickly between the left and right side position, which will force ash to drop into the Ashpan.

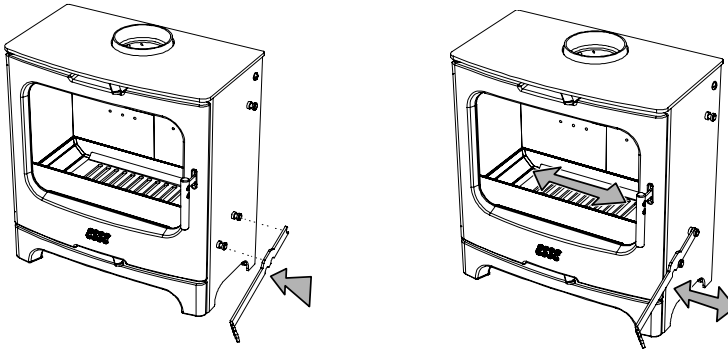

#### Positioning the Fire Grate

The Fire Grate should be ‘closed’, with the Riddle Plate positioned to block the slots in the below Grate. The Fire Grate should only be ‘riddled’ when the ashbed grows above 20mm deep, so as to remove some of the excess ash.

#### ASHPAN



Your ESSE stove will be hot during and after use. Always use the supplied Operating Tool and / or Stove Glove to remove and replace the Ashpan. Only remove the Ashpan when the appliance and ash it contains are cool.

When the Fire Grate is ‘riddled’, ash will fall into the Ashpan below. When the Ashpan is approaching being full, it should be emptied, and the ash disposed of. To remove the Ashpan, insert the folded end of the Operating Tool into the slot at the front of the Ashpan, and carefully pull it forward, sliding it clear of your ESSE stove.

Never allow the level of ash to build up so it touches the underside of the Fire Grate, as this can cause permanent damage to your ESSE stove. Never pour hot ash into plastic waste bags or bins.

## 3. OPERATING INSTRUCTIONS

### CLEANING & MAINTENANCE

Your ESSE stove should be inspected frequently, and any required maintenance undertaken. We recommend that your ESSE stove is serviced once a year by a qualified service professional.



Repairs or modifications should only be undertaken by ESSE authorised professionals. Only genuine ESSE replacement parts should be used, or your warranty may become invalid.

- General cleaning** The exterior cast iron and sheet steel parts should be cleaned with a soft brush or lint-free cloth. Should areas of the appliance need re-painting, high temperature aerosol paints are available from your retailer.
- Catalytic Combustor** Regular inspection of the Catalytic Combustor and Particle Filter is recommended, as described within the Particulate Reburn™ Technology section of this manual.
- Glass Window** If the glass window needs cleaning, use a damp cloth. If stubborn stains remains, use a dedicated glass cleaning solution. Do not use abrasive cleaners or pads, as these can scratch the surface, which may cause the glass to fail prematurely. Before relighting the appliance ensure that the glass has fully dried.
- Rope Seals** Ensuring a firm seal between the body of the appliance and the closed door is essential for the efficient and clean burning of your ESSE stove. The rope seals on the inside face of the door should be inspected regularly, and replaced as necessary.

### CHIMNEY SWEEPING

To ensure continued safe and efficient use of your ESSE stove, we recommend that your chimney is swept by a professional at least once a year, typically before the stove season. Where the appliance is used throughout the year, we recommend more regular sweeping.

### SAFE SHUTDOWN

In the unlikely event of a chimney fire, a fault occurring with the appliance, or extreme weather affecting the burn of the appliance, move the Air Control to the left, closing down the combustion air supply to the minimum volume. This will minimise the intensity of the flames in the appliance, which will then slowly die out. In the case of a fire in the chimney or flue, immediately call the Fire and Rescue Service for assistance.

### SEASONAL USE

If your ESSE stove is to not be used for a period of time, first clean the appliance as described within the 'Cleaning & Maintenance' section of this manual. Empty both the Fire Grate and Ashpan of all ash, before closing the door. Position the Air Control to a central position – This will allow a flow of



### 3. OPERATING INSTRUCTIONS

air, preventing a build-up of moisture inside your ESSE stove, which can lead to rusting. Before re-lighting the appliance, remove the top baffle bricks, to remove any debris, and check for blockages within the flue.

#### WARRANTY

Your ESSE stove has been built to the highest standard using premium materials, and comes with a two year manufacturer's warranty. Register your ESSE stove online at [www.esse.com/warranty-registration](http://www.esse.com/warranty-registration).

The conditions of your warranty are...

- X Does not cover incorrect use or application, as advised within this manual.
- X Must be installed appropriately, by a certified installer.
- X Does not cover consumable parts, including fire grate, glass window, rope door seals, ashpan, vermiculite fire bricks, catalytic combustor or particle filter.
- X Does not cover general wear and tear or cosmetic damage unrelated to the function of the appliance.

#### TROUBLESHOOTING

Problem	Cause	Solution
Window glass blackening	• Wet wood logs	• Use wood logs with 15-20% moisture content
	• Fuel touching glass window	• Use a poker to move fuel back within the fire grate
	• Too little combustion air	• Increase the setting of the air control
Fumes emit into room	• Blocked flue	• Check and remove any blockage
	• Catalytic Combustor may need replacing	• Remove and inspect Catalytic Combustor
Fire will not light	• Too little combustion air	• Increase the setting of the air controller(s)
	• Wet wood logs	• Use wood logs with 15-20% moisture content
	• Flue draft is too low	• Consult with your installer, to rectify

### 3. OPERATING INSTRUCTIONS

Fire burns too quickly	• Too much combustion air	• Reduce the setting of the air control
	• Overly dry wood logs	• Use wood logs with 15-20% moisture content
	• Flue draft is too high	• Consult with your installer, to rectify

#### The Clean Air Act 1993 and Smoke Control Areas

Under the Clean Air Act local authorities may declare the whole or part of the district of the authority to be a smoke control area. It is an offence to emit smoke from a chimney of a building, from a furnace or from any fixed boiler if located in a designated smoke control area. It is also an offence to acquire an “unauthorised fuel” for use within a smoke control area unless it is used in an “exempt” appliance (“exempted” from the controls which generally apply in the smoke control area).

In England appliances are exempted by publication on a list by the Secretary of State in accordance with changes made to sections 20 and 21 of the Clean Air Act 1993 by section 15 of the Deregulation Act 2015. Similarly in Scotland appliances are exempted by publication on a list by Scottish Ministers under section 50 of the Regulatory Reform (Scotland) Act 2014.

In Wales and Northern Ireland these are authorised by regulations made by Welsh Ministers and by the Department of the Environment respectively.

Further information on the requirements of the Clean Air Act can be found here at:  
<https://www.gov.uk/smoke-control-area-rules>

Your local authority is responsible for implementing the Clean Air Act 1993 including designation and supervision of smoke control areas and you can contact them for details of Clean Air Act requirements.

The ESSE 105, 155, 175 multi-fuel stoves have been recommended as suitable for use in smoke control areas when burning wood logs. The ESSE 105, 155, 175 multi-fuel stoves must be fitted with a permanent stop to prevent closure of the air control beyond the 50% open position.

## 4. INSTALLATION INSTRUCTIONS

### PLANNING THE INSTALLATION

It is the installer's responsibility to ensure that when installing the appliance, the requirements of the Health and Safety at Work Act 1974 are met.

The installation instructions within this manual provide a guide for safe and appropriate installation, but it is the responsibility of the installer to ensure that the requirements of applicable British Standards are met, in particular BS 8303 and BS EN 15287:2007, relating to the installation of solid fuel appliances.

When considering the installation design, ensure appropriate access is provided for cleaning of the appliance, flue pipe and chimney flue. This appliance is suitable for intermittent operation, but is not suitable for use in a shared flue system. The appliance should not be used in the same room as an extractor fan, as this can cause the stove to emit fumes into the room.

### VENTILATION

All stoves require a consistent supply of 'combustion air', to allow for combustion of the fire. As a general rule, permanent external air vents are not required for stoves with a nominal output of 5kW or less. However, houses with a low air permeability, such as newer builds, may require a permanent external air vent. Document J of the Building Regulations explains that should a stove be installed in a room with an air permeability of lower than  $5.0\text{m}^3/(\text{h}\cdot\text{m}^2)$ , a permanent external air vent is required, irrespective of the nominal output of the stove. External air vents must be positioned so they are not liable to be blocked. Based upon the requirements within Document J of the Building Regulations, a 5kW stove has the below air vent area requirements.

Air Permeability $\text{m}^3/(\text{h}\cdot\text{m}^2)$	Minimum air vent area ( $\text{cm}^2$ )
	ESSE 100 Series
>5.0	Not required
<5.0	27.5

Please consult Document J of the Building Regulations for detailed guidance, particularly for new build properties, where a low air permeability rating may necessitate a permanent external air vent.

## 4. INSTALLATION INSTRUCTIONS

### PRODUCT SPECIFICATION – 100 SERIES

Key Product Specifications	
	Wood Logs
Nominal Heat Output (Kw)	5.0
Weight (Kg)	97.5
Minimum Flue Draft	12Pa
Flue Gas Mass Flow (g/s)	3.1
Flue temperature (°C)	244
Flue Diameter	5"

Distance To Combustibles		
	Rear (mm)	Sides (mm)
With single wall flue & supplied heatshield	600	600
With double wall flue & optional additional heatshield	75	400

Distance To Non-Combustibles (Recommended)		
	Rear (mm)	Sides (mm)
All configurations	150	150 (75*)

\* Minimum distance required, so as to accommodate the extension of the Bypass Boss, on right hand side of the stove.

### CO ALARM

Building regulations require that whenever a new or replacement fixed solid fuel or wood / biomass appliance is installed in a dwelling, a carbon monoxide (CO) alarm must be fitted in the same room as the appliance, in accordance with BS EN 50292:2002. Please consult Document J of the Building Regulations for detailed guidance. The installation of an alarm must not be considered a substitute for either installing the appliance correctly, or ensuring regular servicing and maintenance of the appliance and chimney system.

### UNPACKING THE APPLIANCE

The stove comes bolted and strapped to a pallet, for simple and secure transportation. To unpack, first remove the strapping and packaging. Then remove the two bolts holding the stove to the pallet, using a 10mm spanner. Locate the four Height Adjusting Bolts supplied with the appliance, and insert them from below into the same four holes in the feet of the stove, using a 13mm spanner. These can then be individually tightened / loosened as required, to level the stove on an uneven / sloping hearth. Whilst heat-treated, the pallet has been produced from timber that is appropriate

## 4. INSTALLATION INSTRUCTIONS

for use as kindling, so can be broken up and chopped, for this purpose. Finally, dispose of the remaining packaging responsibly.

### TOP OR REAR FLUE CONNECTION

The appliance can be installed with either a top or rear connected 5" flue. The stove comes supplied with a top connection, so if a rear connected flue is desired, it must be converted before fitting in place. To convert the stove to rear connection...

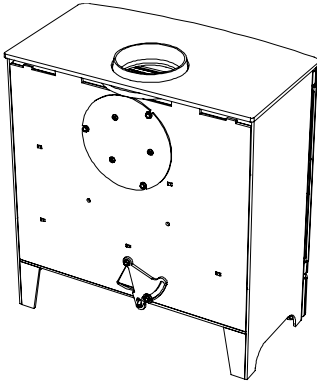

Top flue connection (As factory supplied)

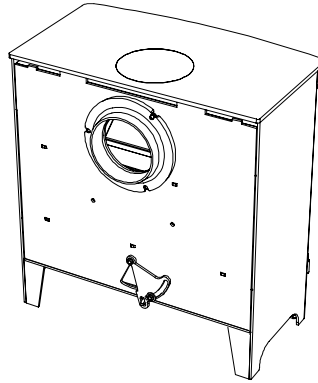

Rear flue connection (After conversion)

1. Remove the flue plate, from the rear of the stove, by unscrewing the three outer fixing screws (using a 13mm spanner).
2. Open the stove door, and remove the two top vermiculite baffle bricks.
3. Remove the two nuts, securing the stove top in place, (using a 13mm spanner), and lift it clear from the stove.
4. Release the cast iron flue collar, by unscrewing the three fixing Philips head bolts.
5. Reposition the cast iron flue collar onto the rear of the stove, (where the flue plate was previously located), reusing the three Philips head bolts.
6. Reposition the flue plate around the top flue port, and fix in place to seal.
7. Replace the stove top into position, and secure using the two retained fixing nuts.
8. Replace the two top vermiculite baffle bricks.
9. Drop the supplied flue blanking disk into the circular cut-out in the stove top.
10. If the flue blanking disk doesn't fit flush with the stove top, remove it and adjust the three inner screws heads on the flue plate, so as to make the blanking disk sit flush.

The stove comes supplied with a steel rear heatshield – This must be included in the installation. If the stove is to be installed with a rear flue connection, the relevant section of the heatshield should be removed. An optional additional heatshield can be purchased, to reduce the distance to combustibles.

## 4. INSTALLATION INSTRUCTIONS

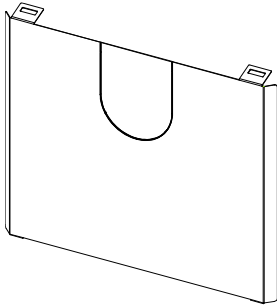

Supplied heatshield

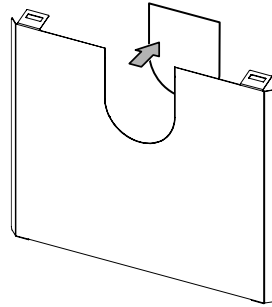

With rear flue knockout removed

### CHIMNEY & FLUE

The stove must be installed and connected to the chimney and flue pipe in line with the current requirements of Building Regulations. As a basic guideline, the chimney and flue installation should...

- ✓ Have an internal cross section area of approximately 320cm<sup>2</sup>, with a minimum diameter or square side length of 125mm<sup>2</sup>.
- ✓ Have a minimum height of 4.5m.
- ✓ Be free from cracks, severe bends, voids and obstructions.
- ✓ Ensure where a flue pipe connects to a chimney, the flue passes past the point where the chimney narrows.
- ✓ Ensure an appropriate flue draft, as detailed within the Flue Draft section of this manual.
- ✓ Take into consideration future access for maintenance and sweeping.

Please consult Document J of the Building Regulations for detailed guidance.

### HEARTH

The hearth must be at least 12mm thick and of non-combustible material(s). When in use, the temperature on the horizontal surface below the stove has been measured at <100°C. There must be a minimum distance of 225mm from the front of the stove, to the front of the hearth. The hearth must be of robust construction, capable of taking the weight of the stove. Please consult Document J of the Building Regulations for detailed guidance.

### CLEARANCE DISTANCES (COMBUSTIBLES & NON-COMBUSTIBLES)

The appliance comes with a rear heatshield, which must be installed, irrespective whether the surrounding materials are combustible or non-combustible. Required distances to combustibles,

## 4. INSTALLATION INSTRUCTIONS

(with the supplied heatshield), can be found in the Product Specification section of this manual. An optional additional heatshield is available, which when installed along with a double wall flue pipe, reduces the permitted distances to combustibles significantly. Recommended distances to non-combustibles are also indicated, in the same section.

However, consideration must also be given to the minimum space required to the right of the appliance, to allow for the Bypass Boss to be opened, as shown below.

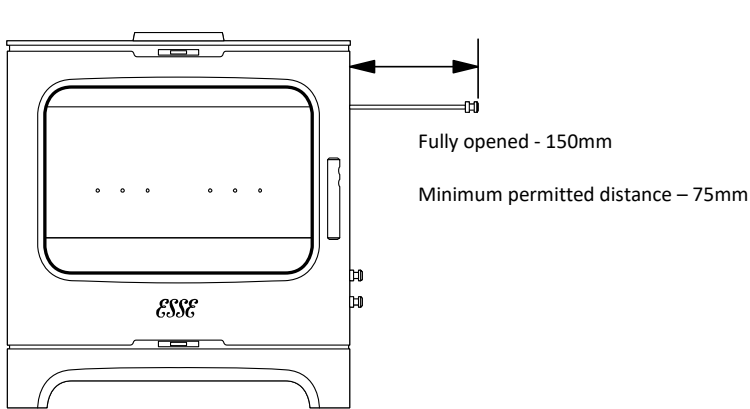

Minimum right side clearance distance, to accommodate the extended Bypass Boss

### FLUE DRAFT

An appropriate flue draft is essential, for the stove to work safely and efficiently. When installed, and prior to commissioning, a flue draft reading should be taken, using the flue draft reading point located in the top of the right hand side of the stove. When both the stove and chimney are warm, a reading in a range between 1.25mm wg (12 Pa) and 2.5mm wg (25 Pa) should be expected. Any readings significantly outside this range are likely to cause problems, so further investigation should be undertaken so as to either reduce or increase the flue draft reading, as appropriate.

### COMMISSIONING

Once the installation has been completed, check the flue and chimney connection is fully sealed, and complete a test lighting of the stove. Instruct the owner on how to use the appliance, and complete the Commissioning Checklist section of this manual. Finally, ensure that you leave this manual with the owner, for their reference.

## 5. APPLIANCE COMMISSIONING CHECKLIST

Please complete, for the owners records and to support any future warranty claims.

### Retailer information:

Name: \_\_\_\_\_

Address: \_\_\_\_\_  
\_\_\_\_\_  
\_\_\_\_\_

Telephone number: \_\_\_\_\_  
\_\_\_\_\_

### Installation information: (Essential information - must be completed)

Date of installation: \_\_\_\_\_

ESSE stove model: \_\_\_\_\_

Serial number: \_\_\_\_\_

### Installing engineer information:

Name: \_\_\_\_\_

Address: \_\_\_\_\_  
\_\_\_\_\_  
\_\_\_\_\_

Telephone number: \_\_\_\_\_  
\_\_\_\_\_

### Commissioning checks: (To be completed & signed for)

Flue draft reading taken and recorded: \_\_\_\_\_ (Insert reading here)

Flue & chimney setup appropriate: Yes  No

Flue & chimney swept & inspected: Yes  No

Smoke test completed on appliance: Yes  No

Clearance to combustibles checked: Yes  No

CO alarm fitted: Yes  No

Operation of appliance explained to owner: Yes  No

Instruction manual handed over to owner: Yes  No

Signature: \_\_\_\_\_ Print name: \_\_\_\_\_



## 6. CONSUMABLE PARTS

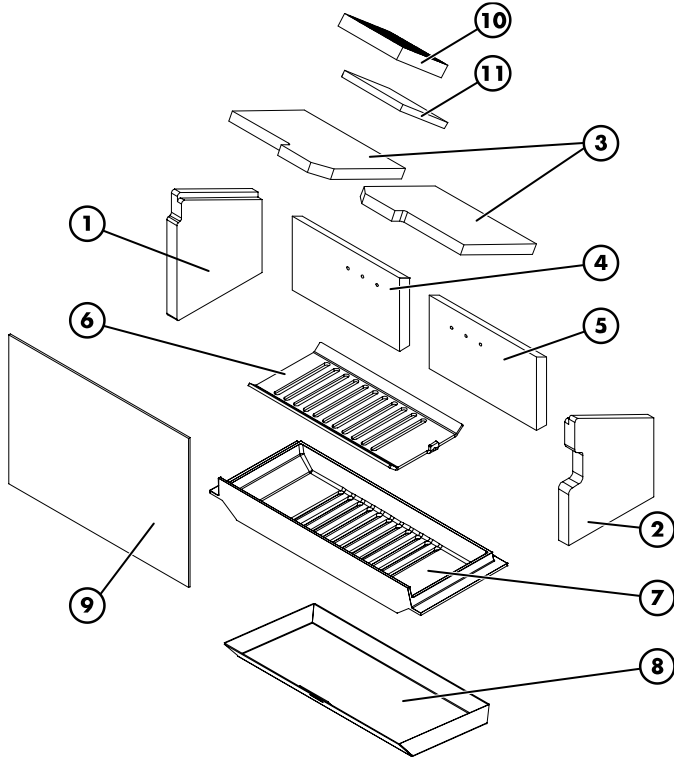

Item	Part No.	Description	Item	Part No.	Description
1	S-MF-110-051	100 Eco Brick LH Side	7	MF1001-RIDDLE	Cast Iron Fire Grate
2	S-MF-110-052	100 Eco Brick RH Side	8	125-014	Ashpan
3	S-MF-110-055	100 Eco Brick Top (X2)	9	S-MF-110-019	Glass Window
4	S-MF-110-053	100 Eco Brick LH Rear	10	S-MF-110-100	Catalytic Combustor
5	S-MF-110-054	100 Eco Brick RH Rear	11	500-IH-001	Particle Filter
6	100-014	Steel Fire Plate			

The above consumable parts can be ordered through your retailer. If your retailer is unable to supply the consumable parts, or you would like to discuss the availability of spare parts, please contact ESSE directly.

## 7. DECLARATION OF PERFORMANCE



### DECLARATION OF PERFORMANCE

(In accordance with Regulation (EU) No. 305/2011)

- Unique identification code of the product type**  
105 / 155 / 175 F / 175 B
- Product description**  
ESSE 105 / ESSE 155 / ESSE 175 F (With feet) / ESSE 175 B (With solid base)
- Intended use of the product**  
Residential roomheater fired by wood logs without hot water supply
- Manufacturer**  
ESSE Engineering Ltd, Ouzledale Foundry, Long Ing, Barnoldswick, Lancashire, UK, BB18 6BJ
- Authorised representative**  
n/a
- System of assessment**  
System 3
- Notified laboratory**  
The notified laboratory KIWA Gastec, laboratory No. 0558 performed the determination of the product type on the basis of type testing under system 3 and issued test report Ref. 61233-1
- Declared performance**

	Wood
• Harmonised technical specification	BS EN 13240:2001 + A2:2004
• Essential characteristics	Performance
• Fire safety	-
- Reaction to fire	A1
- Distance to combustible materials / (With additional heatshield & double wall flue)	Rear: 600mm / (75mm) Sides: 600mm / (400mm)
- Risk of burning fuel escaping	Pass
• Emission of combustible product (CO)	-
- Mean CO [at 13 % O <sub>2</sub> ] (%)	0.02%
- Mean CnHm [at 13 % O <sub>2</sub> ] (Nmg/m <sup>3</sup> )	82
- Mean NOx [at 13 % O <sub>2</sub> ] (Nmg/m <sup>3</sup> )	79
- DIN Plus particulates [at 13 % O <sub>2</sub> ] (Nmg/m <sup>3</sup> )	25
• Surface Temperature	Pass
• Electrical Safety	n/a
• Cleanability	Pass
• Flue gas temperature at nominal heat output	231°C
• Mechanical resistance (to carry a chimney / flue)	Pass
• Thermal properties	-
- Nominal heat output	5.0kW
- Room heating output	5.0kW
- Water heating output	n/a
• Efficiency	83.7%

- Conformity**  
The performance of the product identified in points 1 and 2 is in conformity with the declared performance given in point 8

Signed for on behalf of the manufacturer

Signed M. Ashby Date 14/10/21

Martin Ashby  
Managing Director

R2 10/21

\* IMPORTANT NOTE: Image shows ESSE 175 Multifuel with additional Air Control. ESSE 100 Series Ecodesign Stoves are equipped with a single air control.



**ESSE Engineering Ltd.**  
Long Ing, Barnoldswick, Lancashire, **BB18 6BJ.**

**Website**      [www.esse.com](http://www.esse.com)

R3 230303