

Di Lusso ^{R5 Euro}

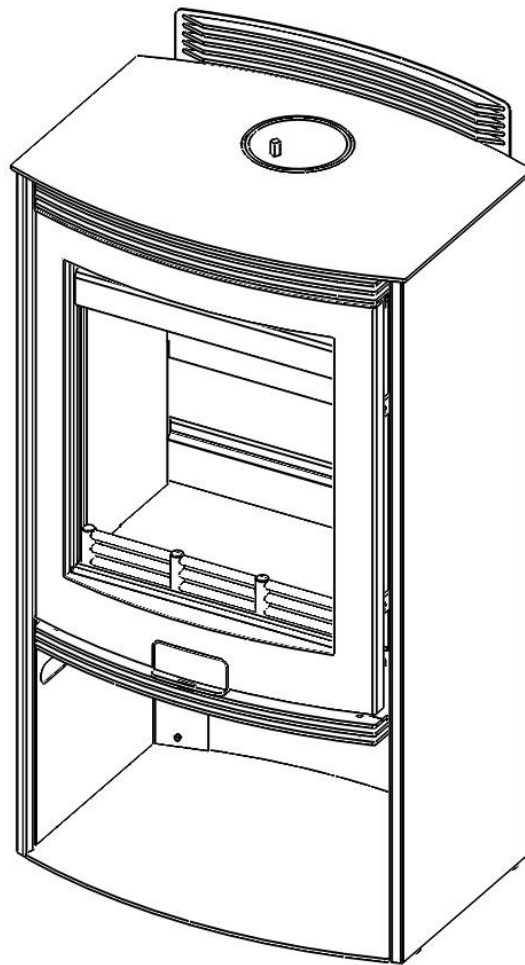

Wood Burning Stove Installation and Operating Instructions

Di Lusso**R5 Euro**

Di Lusso, Emperor Way, Exeter Business Park, Exeter, United Kingdom, EX1 3QS

BSEN13240 – Wood Burning Stove

Appliance Mass	138kg
Efficiency	79%
Nominal Heat Output	4.9kW
Mean Co Emission (@13% O ₂)	0.2%
Mean Flue Gas Temperature	239°C
Flue Gas Mass Flow	5.4g/sec

NS3058/59

Average Particulate Emission	2.54g/kg
------------------------------	----------

Minimum Clearance to Combustible Material

At the sides of the stove (Side wall not protruding in front of stove)	50mm
Behind the stove	10mm
In front of the stove (to furniture etc)	1100mm

This appliance is not suitable for use in a shared flue

This appliance is suitable for intermittent burning

Guarantee

The Body of the stove is covered under a 5-year guarantee (from date of purchase) to be free from defects in materials and workmanship. Internal components other than consumable items such as glass and firebricks are covered for a period of one year from date of purchase.

General Guidance

It is important that your stove is correctly installed as Di Lusso cannot accept responsibility for any fault arising through incorrect use or installation.

These instructions cover the basic principles to ensure satisfactory installation of the stove, although detail may need slight modification to suit particular local site conditions.

The installation must comply with current Building Regulations, national and European standards, Local Authority byelaws and other specifications or regulations as they affect the installation of the stove.

The Building Regulations requirements may also be met by adopting the relevant recommendations in the current issues of British Standards BS 8303 and BS EN 15287-1.

COMPETENT PERSONS SCHEME

Di Lusso recommend that this stove is installed by a member of an accredited competent persons scheme e.g. HETAS.

If the installer is not a member of a competent persons scheme, it is a legal requirement in the UK to notify your local building control body in advance of any work starting.

HEALTH AND SAFETY PRECAUTIONS

Special care must be taken when installing the stove such that the requirements of the Health and Safety at Work Act are met.

PACKAGING

All packaging supplied with this stove can be re-used or recycled. Please contact your local authority for information on recycling schemes in your area.

HANDLING

Adequate facilities must be available for loading, unloading and site handling.

FIRE CEMENT

Some types of fire cement are caustic and should not be allowed to come into contact with the skin. In case of contact, wash immediately with plenty of water.

ASBESTOS

This stove contains no asbestos. If there is a possibility of disturbing any asbestos in the course of installation then please seek specialist guidance and use appropriate protective equipment.

METAL PARTS

When installing or servicing this stove, care should be taken to avoid the possibility of personal injury.

AIR SUPPLY

The room or space containing this appliance should have purpose provided ventilation (where necessary) in accordance with Building Regulations.

Due consideration should be given to air requirements for any other appliance in the same room or space.

Any air opening must be kept clear from blockage or obstruction.

MODIFICATION

No unauthorized modification of this appliance should be carried out.

SAFETY

WARNING – This appliance will be hot when in operation and due care should be taken. The supplied operating tool or gloves may be used to open the door and operate the air controls.

AEROSOLS – Do not use an aerosol spray on or near the stove when it is alight.

FIRES CAN BE DANGEROUS – Always use a fireguard in the presence of children, the elderly or the infirm. The fireguard should be manufactured in accordance with BS8423 – Fireguards for use with solid fuel appliances.

DO NOT OVER-FIRE – it is possible to fire the stove beyond its design capacity. This could damage the stove so watch for signs of over-firing. If any part of the stove starts to glow red, the stove is in an over-fire situation and the controls should be adjusted accordingly. Never leave the stove unattended for long periods without first adjusting the controls to a safe setting. Careful air supply control should be exercised at all times.

FUME EMISSION – properly installed and operated, this appliance will not emit fumes. Occasional fumes from de-ashing and refueling may occur. Persistent fume emission must not be tolerated.

This appliance should not be operated with the door open

If fume emission does persist then the following action should be taken immediately –

- Open Doors and windows to ventilate room.
- Let the fire out, or eject and safely dispose of fuel from the appliance.
- Check for flue/chimney blockage and clean if required.
- Do not attempt to relight the fire until the cause has been identified and corrected.
- If necessary seek professional advice.

ADVERSE WEATHER – In a small number of installations, occasional local weather conditions (e.g. wind from a particular direction) may cause downdraught in the flue and the stove to emit fumes. In these circumstances the stove should not be used. A professional flue installer will be able to advise on solutions to this problem (e.g. anti-downdraught cowl).

EXTRACTOR FANS – DO NOT FIT AN EXTRACTOR FAN IN THE SAME ROOM AS THIS APPLIANCE.

IN THE EVENT OF A CHIMNEY FIRE -

- Raise the alarm
- Call the Fire Brigade
- Close appliance air controls
- Move furniture, ornaments etc away
- Place a fireguard in front of stove
- Check the chimney breast for signs of excessive heat.

If the wall is becoming excessively hot, move furniture away. Ensure the Fire Brigade can gain access to your roof space in order to check for fire spread.

Installation Requirements

(N.B. All dimensions are in Millimetres)

APPLIANCE DIMENSIONS (STRAIGHT SIDES)

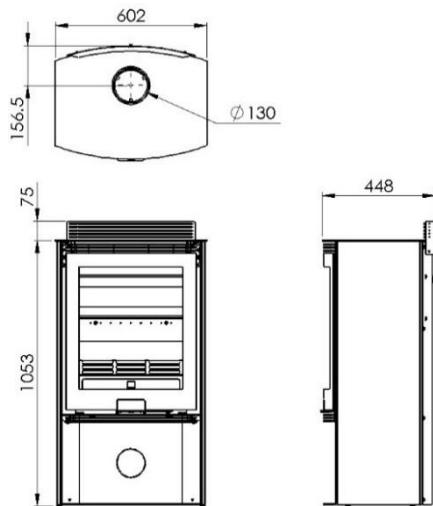

APPLIANCE DIMENSIONS (CURVED SIDES)

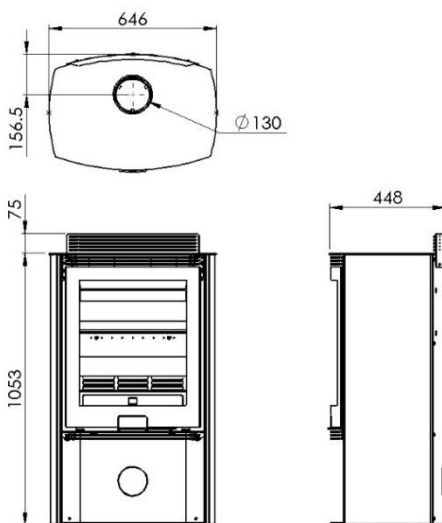

DIRECT AIR ADAPTOR

If fitting the direct air adaptor kit, read the instructions supplied with the kit before proceeding.

HEARTH REQUIREMENTS

Your stove must be installed on a floor with adequate load-bearing capacity, otherwise suitable measures should be taken.

Use the adjusting feet to level the stove.

The stove can be recessed into a suitably sized fireplace. Ensure there is a free air gap of at least 150mm above and 50mm around the sides and rear of the stove.

Where possible it is recommended that a free air gap of 150mm or more is left around the sides of the stove to obtain maximum heat output and to gain access to the rear of the stove.

If the stove is to stand in an appliance recess, it should stand wholly above a solid, non-combustible hearth, at least 125 mm thick (this may include the thickness of a solid floor).

If the stove is not to stand in an appliance recess, it may stand wholly above a hearth made of non-combustible board / sheet material or tiles, at least 12mm thick.

The hearth should extend at least 150 mm from the sides and rear of the stove, and at least 225 mm from the front of the stove.

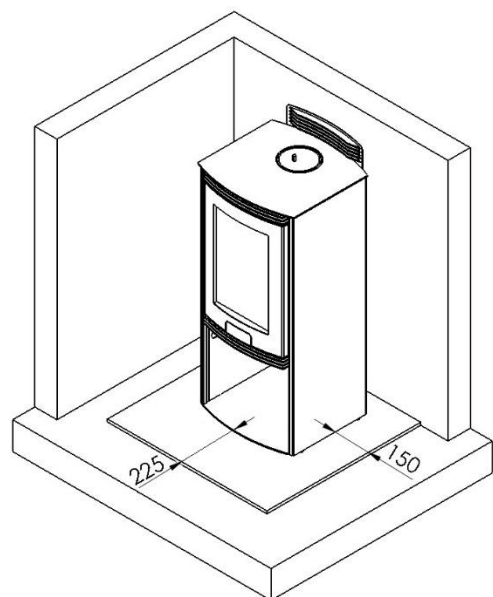

All non-combustible walls closer than 300mm to the stove should be at least 75mm thick.

CLEARANCES TO COMBUSTIBLE MATERIALS

Note: combustible material refers to any material that will degrade when subjected to heat e.g. plaster.

For distances to combustible materials, see table opposite. No combustible furniture should be placed any closer than 900mm from the front of the stove.

Note: To achieve the specified distances to combustible materials, twin-wall insulated flue pipe must be used, starting no higher than 75mm above the stove.

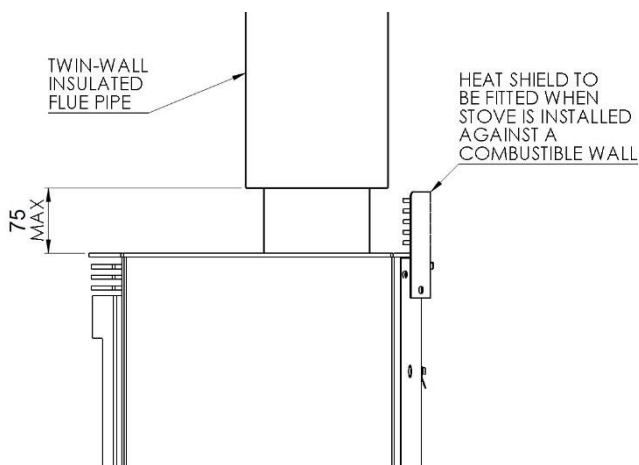

DISTANCES TO COMBUSTIBLE MATERIALS

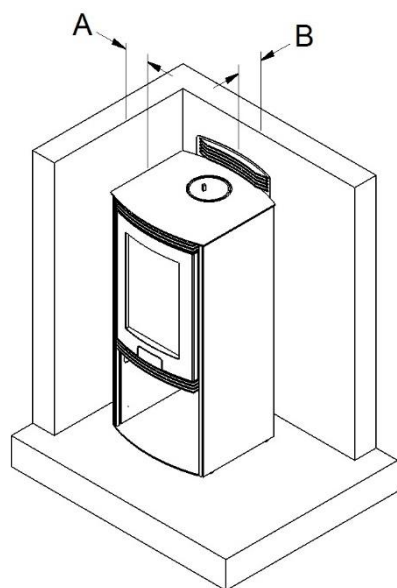

Dimension	Value
A	50 (If side wall does not protrude in front of stove)
B	10 (Behind heat shield)

Any non-combustible walls within 50mm of this appliance should be at least 200mm thick and should extend at least 300mm above the top of the appliance and at least 1.2 metres above the hearth. Any walls more than 50mm from the appliance may be reduced to a thickness of 75mm. Ensure the inter-connecting flue pipe also has adequate clearances to combustible materials.

FUEL STORAGE

Fuel may be stored in the log recess underneath the stove. The logs should be stacked in such a way that they do not touch the heat shield at the top of the recess.

FLUE REQUIREMENTS

The flue serving this appliance must be dry, free from cracks and obstructions and be in accordance with the designations shown in Table 1 on next page.

The diameter of the flue should not be less than 150mm and not more than 200mm.

If these requirements are not met the chimney should be lined by a suitable method.

If there is no existing chimney then either a prefabricated block chimney in accordance with Building Regulations Approved Document J or a twin-walled insulated stainless steel flue to BS EN 1856 can be used. These chimneys must be fitted in accordance with the manufacturer’s instructions and Building Regulations.

Flue Type	Minimum Designation
Masonry or flue block flue with liner	T400 N2 D3 G (BS EN 1443:2003)
Clay Flue Blocks	FB1 N2 (BS EN 1806:2006)
Clay/Ceramic Liners	B1 N2 (BS EN 1457:2009)
Concrete Liners	B2 (BS EN 1857:2003)
Factory Made Metal Chimney	T400 N2 D3 G (BS EN 1856-1:2003)

The chimney/flue should have a vertical height of at least 4.5 metres and should terminate in accordance with Table 2.

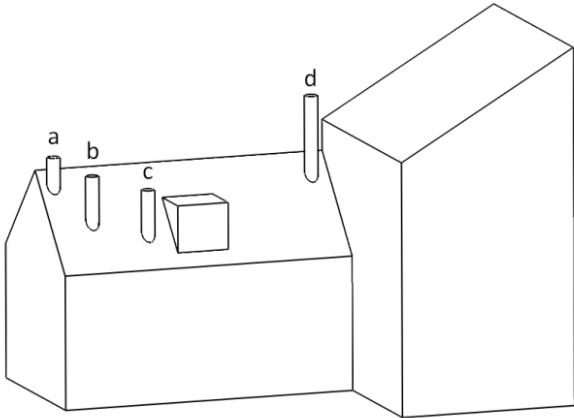

Terminal	Position	Clearances to Flue Outlet
a	At or within 600mm of the ridge	At least 600mm above the ridge
b	Elsewhere on a roof (whether pitched or flat)	At least 2300mm horizontally from the nearest point on the weather surface and: a) At least 1000mm above the highest point of intersection of the chimney and the weather surface or b) At least as high as the ridge
c	Below (on a pitched roof) or within 2300mm horizontally to an openable rooflight, dormer window or	At least 1000mm above the top of the opening.

	other opening.	
d	Within 2300mm of an adjoining or adjacent building, whether or not beyond the boundary.	At least 600mm above any part of the adjacent building within 2300mm

If the chimney is believed to have previously served an open fire installation, it is possible that the higher flue gas temperature from the stove may loosen deposits that were previously firmly adhered, with the consequent risk of flue blockage. It is therefore recommended that the chimney is swept a second time within a month of regular use after installation.

If you have any doubts about the suitability of your chimney, consult your local dealer/stockist. Both the chimney and flue pipe must be accessible for cleaning and if ANY part of the chimney cannot be reached through the stove (with baffle removed), a soot door must be fitted in a suitable position.

FLUE DRAUGHT

If the draught exceeds the recommended maximum, a draught stabiliser must be fitted so that the rate of burning can be controlled and to prevent over firing.

If the reading is less than the recommended minimum then the performance of the appliance will be compromised.

The flue draught should be checked under fire at high output.

Minimum Draught – 1.2mm Water Gauge

Maximum Draught – 2.5mm Water Gauge

INSTALLATION PROCEDURE

Note: If installing the direct air kit, follow the instructions supplied with the kit before proceeding.

1. If installing against a combustible wall, fit the heat shield to the rear of the stove.

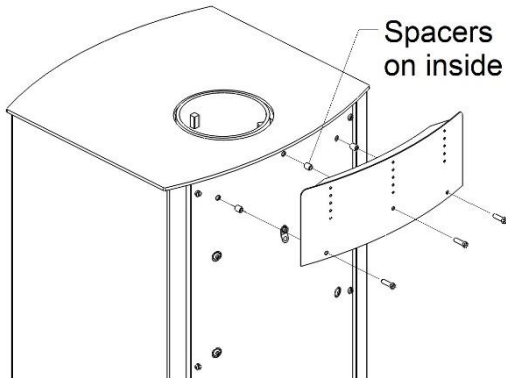

2. Offer the stove into position and adjust the levelling feet as required.

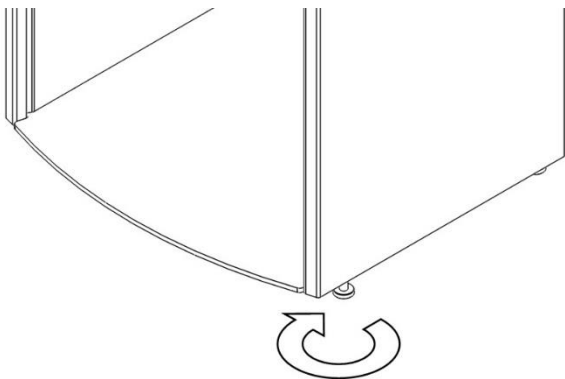

3. Connect the flue, ensuring all joints are sound.

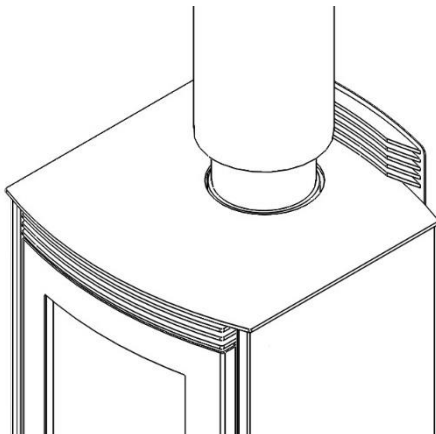

COMMISSIONING

Upon completion of the installation allow a suitable period of time for any fire cement and mortar to dry out. A small fire may then be lit and the installation checked to ensure the smoke and fumes are drawn up the flue and emitted safely to atmosphere. The stove should not be run at full output for at least 24 hours. ***Read the Operating Instructions before lighting the stove for the first time.***

Leave the instructions and operating tool(s) with the customer and advise them on -

- Correct use of the appliance
- The recommended fuel
- Action to be taken should smoke or fumes be emitted from the stove or installation.
- The use of a fireguard when the stove is used in the presence of children or the infirm.

Operating Instructions

Read the 'General Guidance' Section at the start of these instructions before operating your stove for the first time.

WARNING! – This appliance will be hot when in operation and due care should be taken. The supplied operating tool or gloves may be used to open the door and operate the air controls.

RECOMMENDED FUEL

This appliance is designed and approved to burn wood logs with a moisture content not exceeding 20%. The maximum recommended log length is 350mm (14") and the maximum recommended log diameter is 100mm (4").

Do not load fuel higher than the bottom of the compound tertiary cover. (See spares page).

Burn only dry, well-seasoned wood, which should have been cut, split and stacked for at least 12 months, with free air movement around the sides of the stack to enable it to dry out. Burning wet or unseasoned wood will create tar deposits in the stove and chimney, increase harmful emissions and will not produce a satisfactory heat output.

Do not burn waste, mineral fuel, or treated or painted wood in this appliance.

AIR CONTROLS

Installed and used correctly this stove will burn cleanly and efficiently. Therefore, to avoid the disappointment of poor performance or dirty glass, please familiarize yourself with the controls and their recommended settings before use.

To access the air controls pull on the door handle to release it from the magnet and swing it to the right. If the stove is hot, use the tool provided. Insert the end of the tool into the slot in the handle. Alternatively a glove can be used.

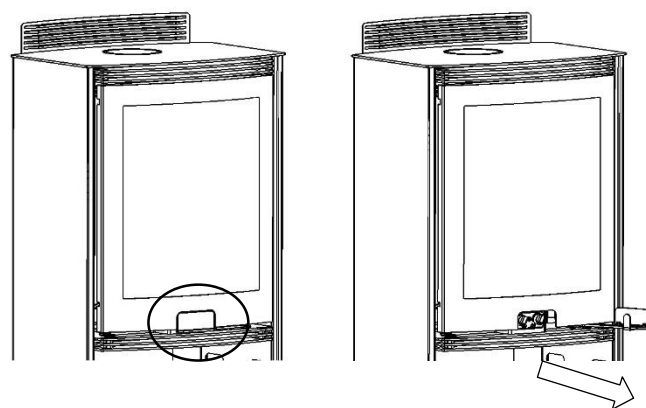

If the door handle is swung past the point where resistance is felt, the door will be unlatched and may swing open.

Ignition Air control – regulates air flow directly into the firebed. This is used when lighting from cold or when reviving a fire that has nearly burnt out. Turn clockwise to open and anti-clockwise to close. **The Ignition Air Control must be closed once the fire is established.**

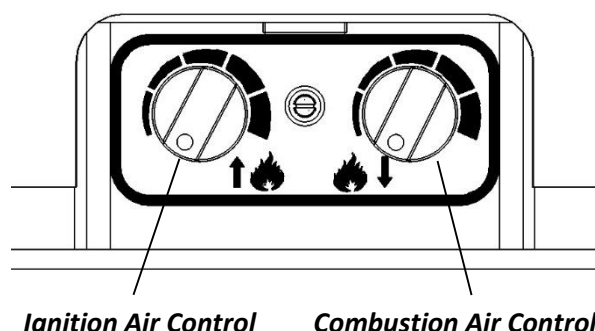

Combustion Air Control – regulates the flow of air downwards into the combustion chamber via the airwash (airflow over the inside of the glass) and the tertiary air inlet (air inlet holes in the back of the firebox). Turn clockwise to open and anti-clockwise to close. **This control is used to regulate the burn rate and therefore heat output of the stove.**

Tertiary Air – Tertiary Air enters the firebox through the series of holes in the rear wall. This air supply helps to reduce emissions into the atmosphere. The tertiary air supply is fixed and cannot be adjusted.

OPENING THE STOVE DOOR

To open the stove door pull on the door handle to release it from the magnet. Swing the handle out to the right until the mechanism engages and the door catch is released.

N.B. When closing the door keep the door handle out to the right until the door is closed.

LIGHTING

We recommend that you have two or three small fires before you operate your stove to its maximum heat output. This is to allow the paint to cure in steadily and to give a long service life to the paint finish. During this curing in process you may notice an unpleasant smell. It is non-toxic, but for your comfort we would suggest that during this period you leave all doors and windows open.

Open both air controls fully and light one or two firelighters placed centrally on the bottom of the firebox, allowing the flames to become established before placing several pieces of small dry kindling in a crisscross fashion above the firelighters, taking care not to smother the fire. Close the stove door.

Once the kindling is well alight open the door and build the fire by gradually adding slightly larger pieces of wood, closing the door afterwards.

Once the fire is established close the Ignition Air Control (anti-clockwise) and add more fuel as necessary. The Combustion Air control can now be used to regulate the burn rate of the stove (see Recommended Settings).

Should the fire fail to light correctly open the door and use a poker to spread the fuel across the bottom of the firebox. Close the door and allow the fuel and stove to cool before attempting to relight the fire.

N.B. Leaving the air controls in the closed position, adding too much fuel or using wood that is wet or too large will prevent the fire from establishing

correctly and may result in smoke emission from the stove.

When the stove is up to operating temperature the operating tool or gloves should be used to operate the air controls.

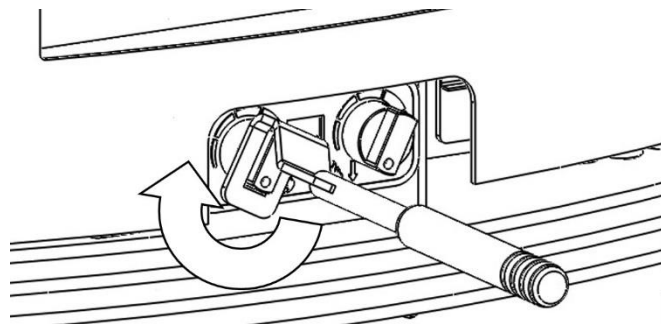

RECOMMENDED SETTINGS

Once the fire is established the Ignition Air Control should be fully closed and the Combustion Air Control turned to a setting of approximately 20 - 30% open. This setting should allow the nominal output and efficiency to be achieved.

Avoid running the stove on very low air settings as this could result in a reduction in efficiency and increase emissions into the atmosphere.

REFUELLING

Avoid refueling on to a low firebed as this may cause excessive smoke emission. Ensure there are sufficient embers to ignite the new fuel load rapidly. Alternatively add some more kindling before adding larger pieces of firewood.

Do not add firewood above the level of the compound tertiary cover at the back of the stove. Exceeding this amount can result in the production of excessive smoke.

DE-ASHING

To remove the ash pan for emptying insert the end of the operating tool into the socket on the ash pan and withdraw it from the grate. ***Do not allow ash to build up to the level of the grate.***

Maintenance

Important! –In order to ensure continued compliance with current Building Regulations, Local Authority Byelaws and the Clean Air Act (if applicable), this appliance requires regular maintenance of the following –

N.B. Refer to the ‘Removing Internal Components’ section of these instructions for details on how to remove each component.

MONTHLY

Brick Baffle – this should be removed and cleaned at least once a month to prevent any build up of soot or ash that could lead to blocked flueways. With the baffle removed the chimney can be swept through the appliance.

Firebricks- in normal use these can last for many years. It is possible, however, to damage them if care is not taken when refueling the stove. Check periodically for seriously cracked bricks, which can be replaced with new, available from your dealer.

Air Valve Cassette- this should be removed and cleaned monthly to remove any ash that may be in the controls. **N.B. Make sure that controls are in the maximum position (fully clockwise) before removing the Air Valve Cassette.**

Glass Panel- clean the glass panel when cool with a proprietary glass cleaner. Highly abrasive substances should be avoided as these can scratch the glass and make subsequent cleaning more difficult.

ANNUALLY

Annual maintenance of the following should be carried out by a competent person –

Chimney and flueways- it is important that the chimney, flueways and any connecting pipe are swept regularly. This means at least twice a year for Woodburning appliances. Only wire-centred sweeps’ brushes fitted with a guide wheel should be used. If it is not possible to sweep all parts of

the chimney through the appliance, ensure there is adequate access to cleaning doors.

If the stove is fitted in place of an open fire the chimney should be swept one month after installation to clear any soot falls which may have occurred due to the difference in combustion between the stove and the open fire.

PERIODS OF PROLONGED NON-USE

If the stove is to be left unused for a prolonged period, then it should be given a thorough clean to remove ash and unburned fuel residues. To enable a good flow of air through the appliance to reduce condensation and subsequent damage, leave the air controls fully open.

If the appliance has been unused for a long period, such as during the spring and summer months, a competent person should check the chimney for potential obstructions before lighting the stove **i.e. get the chimney swept before the start of the heating season.**

AS NECESSARY

Stove body – the stove is finished with a heat resistant paint and this can be cleaned with a soft brush. Do not clean the stove whilst it is hot; wait until it has cooled down.

Door Catch – Over time the rope seal in the door will become compressed. It may therefore be necessary to adjust the door catch to maintain the door seal. To adjust the catch slacken the two set screws on the catch bar and adjust the position of the catch bar as necessary.

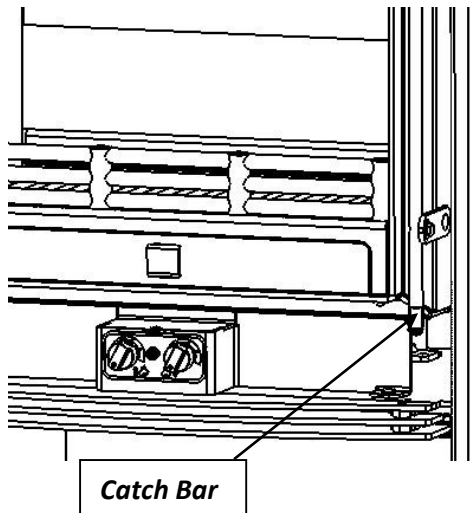

Air Valves - Over time the sealing face of the air valves may wear. This will reduce the effectiveness of the controls. To replace a worn valve remove the air valve cassette, lift off the worn valve and replace with new.

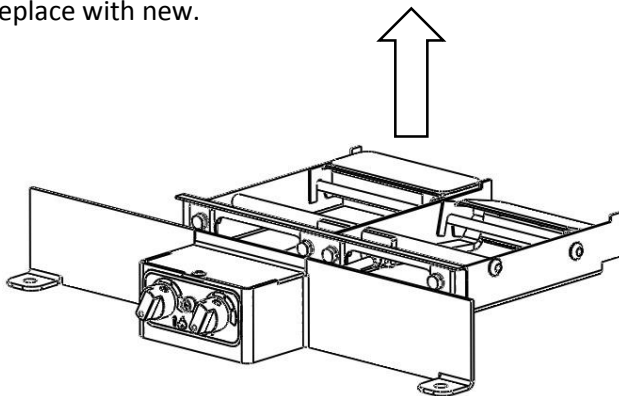

Trouble Shooting

FIRE WILL NOT BURN

Check that –

- Chimneys and flueways are clear.
- A suitable fuel is being used.
- There is an adequate air supply into the room.
- An extractor fan is not fitted in the same room as the stove.
- Flue draught is above minimum level (see installation instructions).

FIRE BLAZING OUT OF CONTROL

Check that –

- The door is tightly closed.
- The air controls are in the closed position.
- A suitable fuel is being used.
- The glass is not loose.
- The door rope seal is in good condition.
- The air valve sealing faces are not worn
- Flue draught is below maximum level (see installation instructions).

REMOVING INTERNAL COMPONENTS

1. To open the stove door, pull on the door lever to release it from the magnet. Swing the handle out to the right until the mechanism engages and the door catch is released.

N.B. When closing the door keep the door handle out to the right until the door is closed.

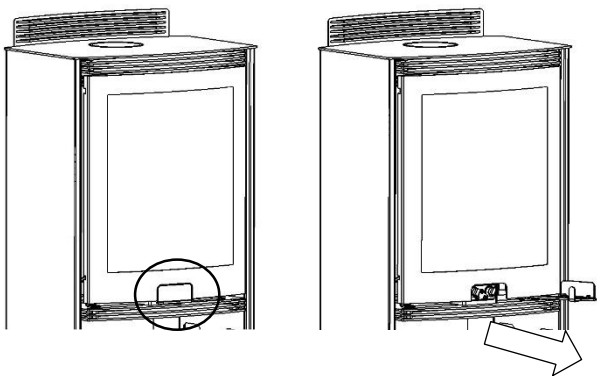

N.B. from this point forward, the door has been hidden for illustrative purposes.

2. Remove the log retainer by lifting it clear of the two support pins.

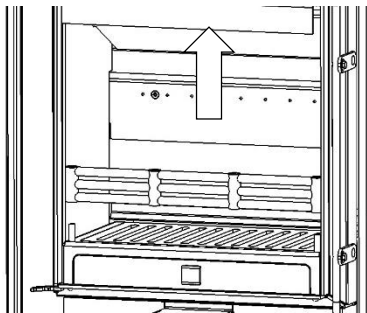

3. Remove the Ashpan by sliding forward out of the stove.

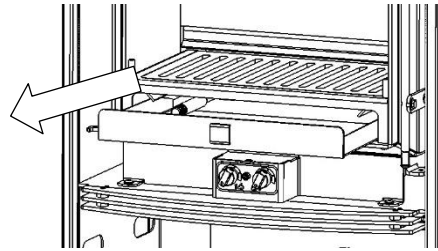

4. Remove the Grate by lifting the front clear of the Grate Support Frame and removing from the stove.

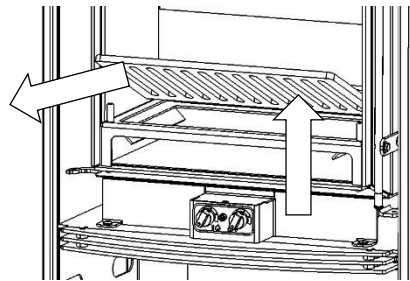

5. Remove the Grate Support Frame by lifting the front up until it is free from the ignition bar before sliding out of the stove.

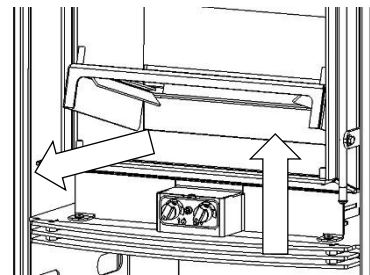

6. Remove the Baffle Brick by lifting it and sliding to the right or left to free it from the side bricks before lowering it into the firebox and removing it.

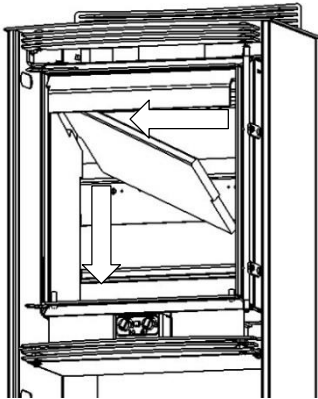

7. Remove the two side bricks by lifting them up to release them from the slots in the base brick. Swing the bricks into the centre and remove them from the firebox.

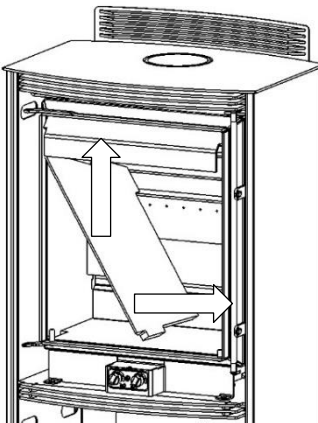

8. Remove the two Rear Bricks by swinging the base of each brick towards the front of the stove.

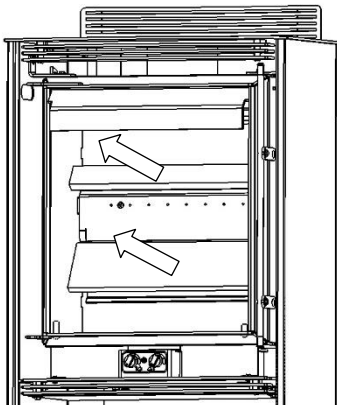

9. Lift up and remove the Base Brick.

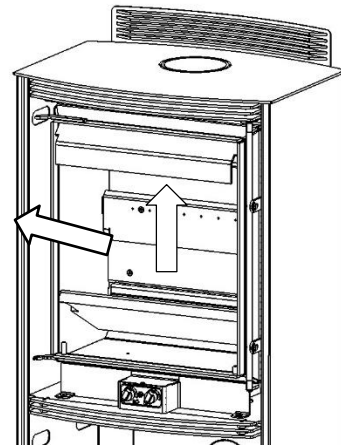

10. Remove the Air Valve Cassette by removing the socket screws holding it in place, turning both air controls to the fully open position (clockwise) and then gently pulling on the fascia to slide the cassette out from under the firebox.
N.B. DO NOT Remove the Air Valve Cassette with the controls in the closed position as this will damage the valve gaskets.

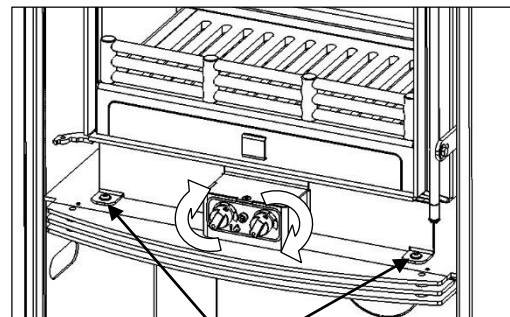

Socket Screws

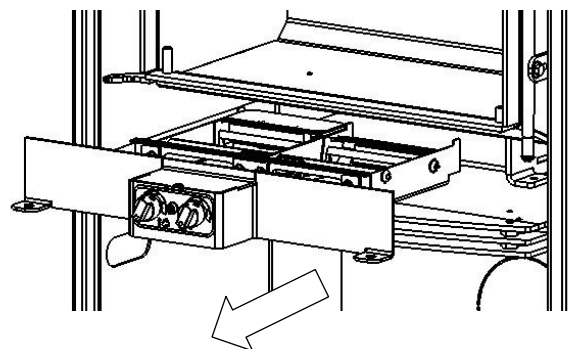

Stove Spares

BODY SPARES

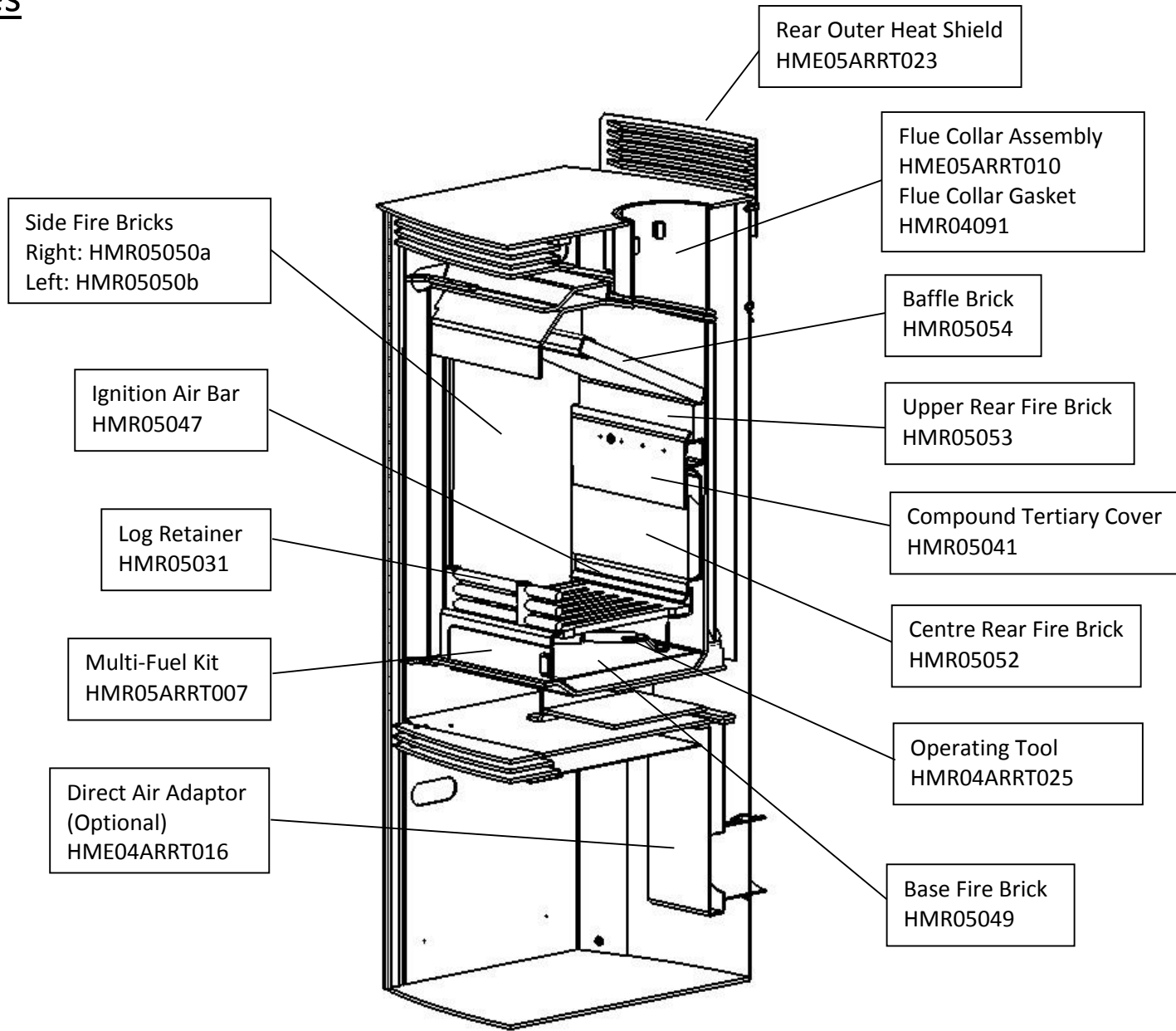

Stove Spares

DOOR SPARES

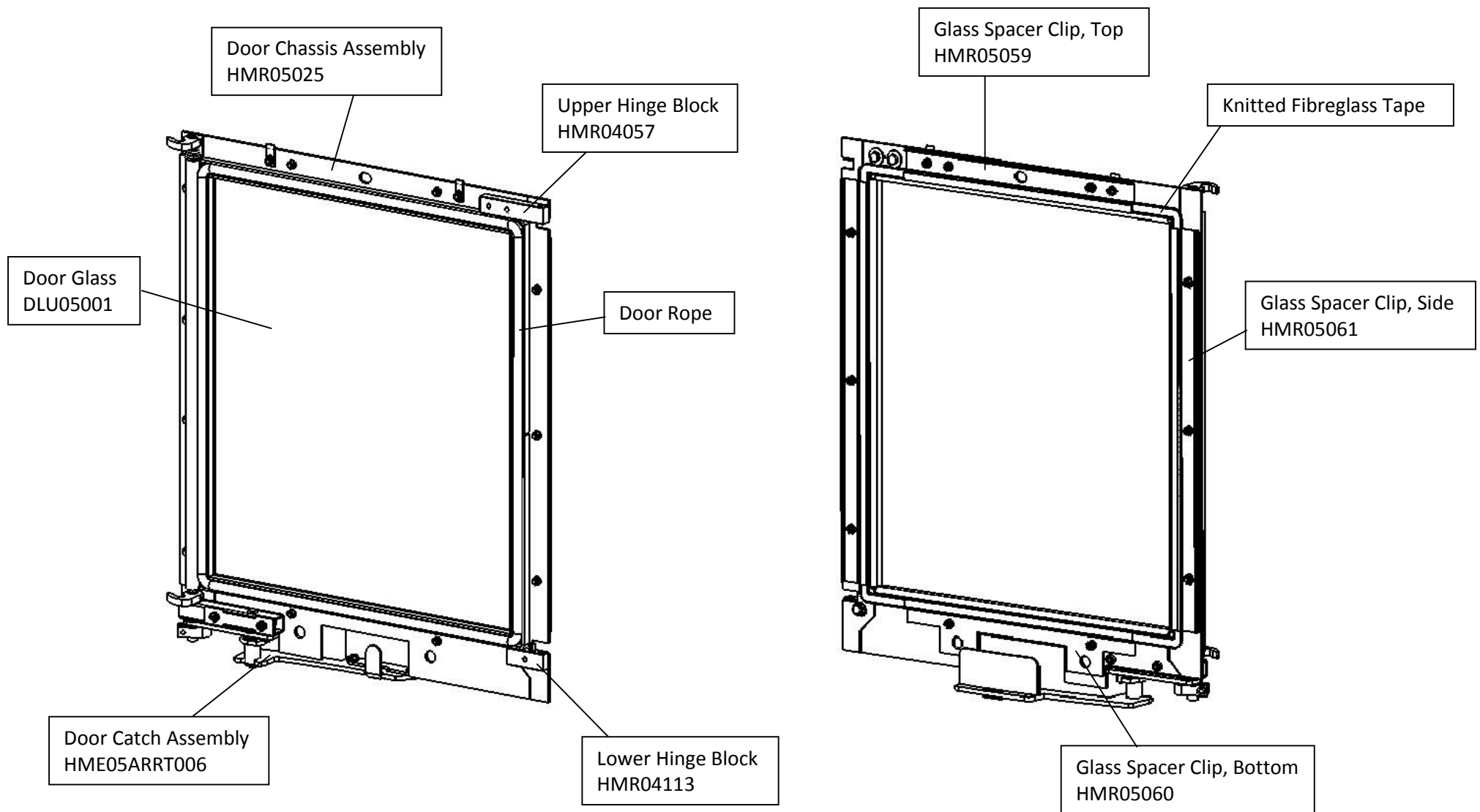

Complete Door Code: HME05ARRT027

Stove Spares

AIR VALVE CASSETTE SPARES

